

# Twelve Output Differential Buffer for PCIe Gen1/Gen2, QPI, and FBDIMM

# ICS9DB1200C

## Description

DB1200 Rev 2.0 Intel Yellow Cover Device

## Description

The ICS9DB1200 is an Intel DB1200 Differential Buffer Specification device. This buffer provides 12 differential clocks at frequencies ranging from 100MHz to 400 MHz. The ICS9DB1200 is driven by a differential output from a CK410B+ or CK509B main clock generator.

## Output Features

- 12 - 0.7V current-mode differential output pairs.
- Supports zero delay buffer mode and fanout mode.
- Bandwidth programming available.
- 100-400 MHz operation in PLL mode
- 33-400 MHz operation in Bypass mode

## Features/Benefits

- 3 selectable SMBus addresses for easy system expansion
- Spread spectrum modulation tolerant, 0 to -0.5% down spread and +/- 0.25% center spread
- Supports undriven differential outputs in Power Down Mode for power management.

## Key Specifications

- Output cycle-cycle jitter < 50ps.
- Output to output skew: 50ps
- Phase jitter: PCIe Gen2 < 3.1ps rms
- Phase jitter: QPI < 0.5ps rms
- 64-pin TSSOP Package
- Available in RoHS compliant packaging

## Functional Block Diagram

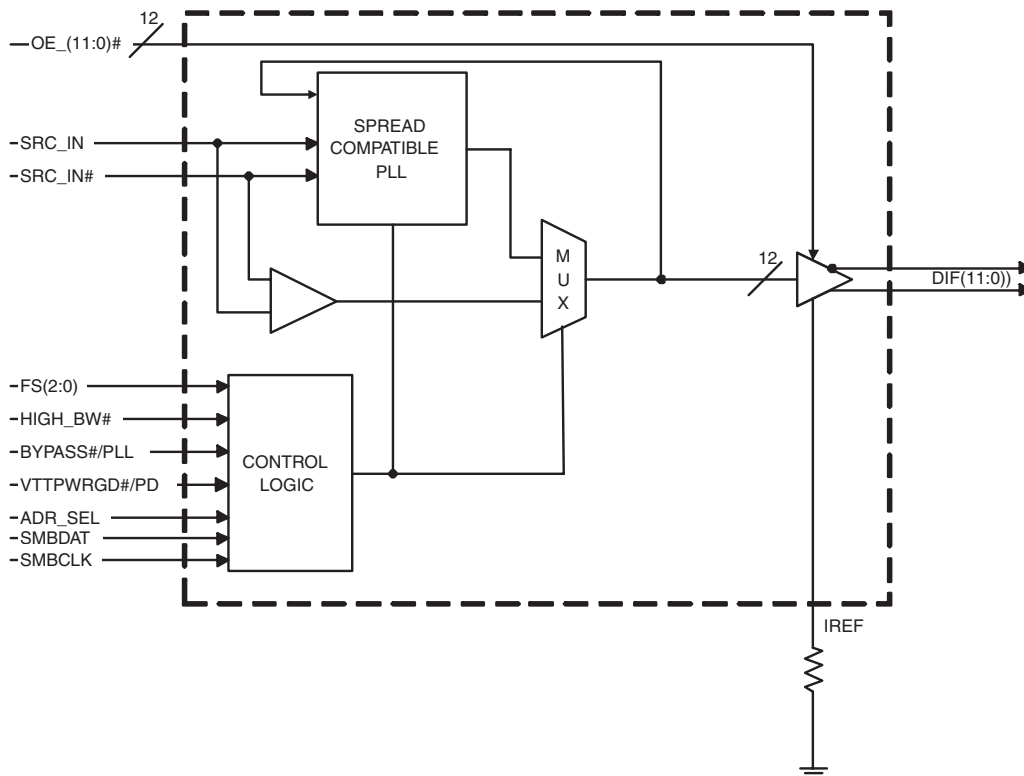

## Pin Configuration

VDD	1	<b>9DB1200C</b>	64	VDDA
DIF_IN	2		63	AGND
DIF_IN#	3		62	IREF
GND	4		61	FS0
OE0#	5		60	OE11#
DIF_0	6		59	DIF_11
DIF_0#	7		58	DIF_11#
VDD	8		57	VDD
GND	9		56	GND
OE1#	10		55	OE10#
DIF_1	11		54	DIF_10
DIF_1#	12		53	DIF_10#
OE2#	13		52	OE9#
DIF_2	14		51	DIF_9
DIF_2#	15		50	DIF_9#
GND	16		49	GND
VDD	17		48	VDD
OE3#	18		47	OE8#
DIF_3	19		46	DIF_8
DIF_3#	20		45	DIF_8#
OE4#	21		44	OE7#
DIF_4	22		43	DIF_7
DIF_4#	23		42	DIF_7#
VDD	24		41	VDD
GND	25		40	GND
OE5#	26		39	OE6#
DIF_5	27		38	DIF_6
DIF_5#	28		37	DIF_6#
**ADR_SEL	29		36	VTTPWRGD#/PD
HIGH_BW#	30		35	BYPASS#/PLL
FS2	31		34	FS1
SMBCLK	32		33	SMBDAT

**64-TSSOP**

\*\* Indicates 120K ohm Pulldown

### Frequency Select Table

FS <sub>L2</sub> B0b2	FS <sub>L1</sub> B0b1	FS <sub>L0</sub> B0b0	Input MHz	DIF <sub>x</sub> ; MHz
0	0	0	266.66	266.66
0	0	1	133.33	133.33
0	1	0	200.00	200.00
0	1	1	166.66	166.66
1	0	0	333.33	333.33
1	0	1	100.00	100.00
1	1	0	400.00	400.00
1	1	1	Hi-Z	Hi-Z

1. FS<sub>L</sub>(2:0) are 3.3V tolerant low-threshold inputs.

Please see VIL\_FS and VIH\_FS specifications in the Input/Supply/Common Output Parameters Table for correct values.

### SMBus Address Selection (Pin 29)

ADR_SEL	Voltage	SMBus Adr (Wr/Rd)
Low	<0.8V	DC/DD
Mid	1.2<Vin<1.8V	D6/D7
High	Vin > 2.0V	D4/D5

### Power Groups

Pin Number		Description
VDD	GND	
2	3	SRC_IN/SRC_IN#
8, 17, 24, 41, 48, 57	9, 16, 25, 40, 49, 56	DIF(11:0)
N/A	63	IREF
64	63	Analog VDD & GND for PLL core

## Pin Description

PIN #	PIN NAME	TYPE	DESCRIPTION
1	VDD	PWR	Power supply, nominal 3.3V
2	DIF_IN	IN	0.7 V Differential TRUE input
3	DIF_IN#	IN	0.7 V Differential Complementary Input
4	GND	PWR	Ground pin.
5	OE0#	IN	Active low input for enabling DIF pair 0. 1 = tri-state outputs, 0 = enable outputs
6	DIF_0	OUT	0.7V differential true clock output
7	DIF_0#	OUT	0.7V differential complement clock output
8	VDD	PWR	Power supply, nominal 3.3V
9	GND	PWR	Ground pin.
10	OE1#	IN	Active low input for enabling DIF pair 1. 1 = tri-state outputs, 0 = enable outputs
11	DIF_1	OUT	0.7V differential true clock output
12	DIF_1#	OUT	0.7V differential complement clock output
13	OE2#	IN	Active low input for enabling DIF pair 2. 1 = tri-state outputs, 0 = enable outputs
14	DIF_2	OUT	0.7V differential true clock output
15	DIF_2#	OUT	0.7V differential complement clock output
16	GND	PWR	Ground pin.
17	VDD	PWR	Power supply, nominal 3.3V
18	OE3#	IN	Active low input for enabling DIF pair 3. 1 = tri-state outputs, 0 = enable outputs
19	DIF_3	OUT	0.7V differential true clock output
20	DIF_3#	OUT	0.7V differential complement clock output
21	OE4#	IN	Active low input for enabling DIF pair 4. 1 = tri-state outputs, 0 = enable outputs
22	DIF_4	OUT	0.7V differential true clock output
23	DIF_4#	OUT	0.7V differential complement clock output
24	VDD	PWR	Power supply, nominal 3.3V
25	GND	PWR	Ground pin.
26	OE5#	IN	Active low input for enabling DIF pair 5. 1 = tri-state outputs, 0 = enable outputs
27	DIF_5	OUT	0.7V differential true clock output
28	DIF_5#	OUT	0.7V differential complement clock output
29	**ADR_SEL	IN	This tri-level input selects one of 3 SMBus addresses. See the SMBus Address Select Table for the addresses.
30	HIGH_BW#	IN	3.3V input for selecting PLL Band Width 0 = High, 1 = Low
31	FS2	IN	Frequency select pin.
32	SMBCLK	IN	Clock pin of SMBUS circuitry, 5V tolerant

## Pin Description

PIN #	PIN NAME	TYPE	DESCRIPTION
33	SMBDAT	I/O	Data pin of SMBUS circuitry, 5V tolerant
34	FS1	IN	3.3V Frequency select latched input pin.
35	BYPASS#/PLL	IN	Input to select Bypass(fan-out) or PLL (ZDB) mode 0 = Bypass mode, 1= PLL mode
36	VTTTPWRGD#/PD	IN	VTTTPWRGD# is an active low input used to sample latched inputs and allow the device to Power Up. PD is an asynchronous active high input pin used to put the device into a low power state. The internal clocks and PLLs are stopped.
37	DIF_6#	OUT	0.7V differential complement clock output
38	DIF_6	OUT	0.7V differential true clock output
39	OE6#	IN	Active low input for enabling DIF pair 6. 1 = tri-state outputs, 0 = enable outputs
40	GND	PWR	Ground pin.
41	VDD	PWR	Power supply, nominal 3.3V
42	DIF_7#	OUT	0.7V differential complement clock output
43	DIF_7	OUT	0.7V differential true clock output
44	OE7#	IN	Active low input for enabling DIF pair 7. 1 = tri-state outputs, 0 = enable outputs
45	DIF_8#	OUT	0.7V differential complement clock output
46	DIF_8	OUT	0.7V differential true clock output
47	OE8#	IN	Active low input for enabling DIF pair 8. 1 = tri-state outputs, 0 = enable outputs
48	VDD	PWR	Power supply, nominal 3.3V
49	GND	PWR	Ground pin.
50	DIF_9#	OUT	0.7V differential complement clock output
51	DIF_9	OUT	0.7V differential true clock output
52	OE9#	IN	Active low input for enabling DIF pair 9. 1 = tri-state outputs, 0 = enable outputs
53	DIF_10#	OUT	0.7V differential complement clock output
54	DIF_10	OUT	0.7V differential true clock output
55	OE10#	IN	Active low input for enabling DIF pair 10. 1 = tri-state outputs, 0 = enable outputs
56	GND	PWR	Ground pin.
57	VDD	PWR	Power supply, nominal 3.3V
58	DIF_11#	OUT	0.7V differential complement clock output
59	DIF_11	OUT	0.7V differential true clock output
60	OE11#	IN	Active low input for enabling DIF pair 11. 1 = tri-state outputs, 0 = enable outputs
61	FS0	IN	3.3V Frequency select latched input pin.
62	IREF	OUT	This pin establishes the reference current for the differential current-mode output pairs. This pin requires a fixed precision resistor tied to ground in order to establish the appropriate current. 475 ohms is the standard value.
63	AGND	PWR	Analog Ground pin for Core PLL
64	VDDA	PWR	3.3V power for the PLL core.

## Absolute Max

Symbol	Parameter	Min	Max	Units
VDDA	3.3V Core Supply Voltage		4.6	V
VDD	3.3V Logic Supply Voltage		4.6	V
V <sub>IL</sub>	Input Low Voltage	GND-0.5		V
V <sub>IH</sub>	Input High Voltage		V <sub>DD</sub> +0.5V	V
T <sub>s</sub>	Storage Temperature	-65	150	°C
T <sub>ambient</sub>	Ambient Operating Temp	0	70	°C
T <sub>case</sub>	Case Temperature		115	°C
ESD prot	Input ESD protection human body model	2000		V

## Electrical Characteristics - Input/Supply/Common Output Parameters

T<sub>A</sub> = 0 - 70°C; Supply Voltage V<sub>DD</sub> = 3.3 V +/-5%

PARAMETER	SYMBOL	CONDITIONS	MIN	TYP	MAX	UNITS	NOTES
Input High Voltage	V <sub>IH</sub>	3.3 V +/-5%	2		V <sub>DD</sub> + 0.3	V	
Input Low Voltage	V <sub>IL</sub>	3.3 V +/-5%	GND - 0.3		0.8	V	
Input High Current	I <sub>IH</sub>	V <sub>IN</sub> = V <sub>DD</sub>	-5		5	uA	
Input Low Current	I <sub>IL1</sub>	V <sub>IN</sub> = 0 V; Inputs with no pull-up resistors	-5			uA	
	I <sub>IL2</sub>	V <sub>IN</sub> = 0 V; Inputs with pull-up resistors	-200			uA	
Operating Supply Current	I <sub>DD3.3OP</sub>	Full Active, C <sub>L</sub> = Full load;		263	350	mA	1
Powerdown Current	I <sub>DD3.3PD</sub>	all differential pairs tri-stated		24	30	mA	1
Input Frequency	F <sub>iPLL</sub>	PLL Mode	100		400	MHz	1
	F <sub>iBYPASS</sub>	Bypass Mode	33		400	MHz	1
Pin Inductance	L <sub>pin</sub>				7	nH	1
Capacitance	C <sub>IN</sub>	Logic Inputs	1.5		5	pF	1
	C <sub>OUT</sub>	Output pin capacitance			6	pF	1
PLL Bandwidth	BW	PLL Bandwidth when PLL_BW=0	2	3	4	MHz	1
		PLL Bandwidth when PLL_BW=1	0.7	1	1.4	MHz	1
Clk Stabilization	T <sub>STAB</sub>	From V <sub>DD</sub> Power-Up and after input clock stabilization or de-assertion of PD# to 1st clock			1	ms	1,2
Modulation Frequency	f <sub>MOD</sub>	Triangular Modulation	30		33	kHz	1
OE# Latency	t <sub>LATOE#</sub>	DIF start after OE# assertion DIF stop after OE# deassertion	4		12	cycles	1,3
Tdrive_PD	t <sub>DRVPD</sub>	DIF output enable after PD de-assertion			300	us	1,3
Tfall	t <sub>F</sub>	Fall time of OE#			5	ns	1
Trise	t <sub>R</sub>	Rise time of OE#			5	ns	2

<sup>1</sup>Guaranteed by design and characterization, not 100% tested in production.<sup>2</sup>See timing diagrams for timing requirements.<sup>3</sup>Time from deassertion until outputs are >200 mV

## Electrical Characteristics - Clock Input Parameters

$T_A = 0 - 70^\circ\text{C}$ ; Supply Voltage  $V_{DD} = 3.3\text{ V} \pm 5\%$

PARAMETER	SYMBOL	CONDITIONS	MIN	TYP	MAX	UNITS	NOTES
Input High Voltage - DIF_IN	$V_{IH\text{DIF}}$	Differential inputs (single-ended measurement)	600	800	1150	mV	1
Input Low Voltage - DIF_IN	$V_{IL\text{DIF}}$	Differential inputs (single-ended measurement)	$V_{SS} - 300$	0	300	mV	1
Input Common Mode Voltage - DIF_IN	$V_{COM}$	Common Mode Input Voltage	300		1000	mV	1
Input Amplitude - DIF_IN	$V_{SWING}$	Peak to Peak value	300		1450	mV	1
Input Slew Rate - DIF_IN	dv/dt	Measured differentially	0.4		8	V/ns	1,2
Input Leakage Current	$I_{IN}$	$V_{IN} = V_{DD}$ , $V_{IN} = \text{GND}$	-5		5	$\mu\text{A}$	1
Input Duty Cycle	$d_{\text{tin}}$	Measurement from differential waveform	45		55	%	1
Input Jitter - Cycle to Cycle	$J_{\text{DIFin}}$	Differential Measurement	0		125	ps	1

<sup>1</sup> Guaranteed by design and characterization, not 100% tested in production.

<sup>2</sup> Slew rate measured through  $V_{\text{swing min}}$  centered around differential zero

## Electrical Characteristics - DIF 0.7V Current Mode Differential Pair

$T_A = 0 - 70^\circ\text{C}$ ;  $V_{DD} = 3.3\text{ V} \pm 5\%$ ;  $C_L = 2\text{pF}$ ,  $R_S = 33.2\Omega$ ,  $R_P = 49.9\Omega$ ,  $R_{REF} = 475\Omega$

PARAMETER	SYMBOL	CONDITIONS	MIN	TYP	MAX	UNITS	NOTES
Current Source Output Impedance	$Z_o^1$	$V_O = V_x$	3000			$\Omega$	1
Voltage High	VHigh	Statistical measurement on single ended signal using oscilloscope math function.	660		850	mV	1,3
Voltage Low	VLow		-150		150		1,3
Max Voltage	Vovs	Measurement on single ended signal using absolute value.			1150	mV	1
Min Voltage	Vuds		-300				1
Crossing Voltage (abs)	Vcross(abs)		250		550	mV	1
Crossing Voltage (var)	d-Vcross	Variation of crossing over all edges			140	mV	1
Long Accuracy	ppm	see Tperiod min-max values			0	ppm	1,2
Rise Time	$t_r$	$V_{OL} = 0.175\text{V}$ , $V_{OH} = 0.525\text{V}$	175		700	ps	1
Fall Time	$t_f$	$V_{OH} = 0.525\text{V}$ , $V_{OL} = 0.175\text{V}$	175		700	ps	1
Rise Time Variation	d- $t_r$				125	ps	1
Fall Time Variation	d- $t_f$				125	ps	1
Duty Cycle	$d_{t3}$	Measurement from differential waveform	45		55	%	1
Skew	$t_{\text{sk}3}$	$V_T = 50\%$			50	ps	1
Jitter, Cycle to cycle	$t_{\text{jyc-cyc}}$	PLL mode			50	ps	1,5
		BYPASS mode as additive jitter			50	ps	1,5

<sup>1</sup> Guaranteed by design and characterization, not 100% tested in production.

<sup>2</sup> All Long Term Accuracy specifications are guaranteed with the assumption that the input clock complies with CK410B/CK509B accuracy requirements. The 9DB1200 itself does not contribute to ppm error.

<sup>3</sup>  $I_{REF} = V_{DD}/(3 \times R_R)$ . For  $R_R = 475\Omega$  (1%),  $I_{REF} = 2.32\text{mA}$ .  $I_{OH} = 6 \times I_{REF}$  and  $V_{OH} = 0.7\text{V}$  @  $Z_O = 50\Omega$ .

<sup>4</sup> Applies to Bypass Mode Only

<sup>5</sup> Measured from differential waveform

**Electrical Characteristics - Phase Jitter**

PARAMETER	SYMBOL	CONDITIONS*	MIN	TYP.	MAX	UNITS	NOTES
Jitter, Phase	tjphase	PCIe Gen 1 specs (1.5 - 22 MHz)			108	ps	1,2
		PCIe Gen 2 (8-16 MHz, 5-16 MHz) Lo-band content (10kHz to 1.5MHz)			3	ps rms	1,2
		PCIe Gen 2 (8-16 MHz, 5-16 MHz) Hi-band content (1.5MHz to Nyquist)			3.1	ps rms	1,2
		PCIe Gen 2 (8-16 MHz, 5-16 MHz) Hi-band content (1.5MHz to Nyquist)			3.1	ps rms	1,2
		3G FBD specs (11-33 MHz)			3	ps rms	2
		QPI specs (133MHz)			0.5	ps rms	2

**Notes on Phase Jitter:**

<sup>1</sup> See <http://www.pcisig.com> for complete specs. Guaranteed by design and characterization, not tested in production.

<sup>2</sup> Device driven by 932S421BGLF or equivalent

SRC Reference Clock			
Common Recommendations for Differential Routing	Dimension or Value	Unit	Figure
L1 length, Route as non-coupled 50 ohm trace.	0.5 max	inch	1
L2 length, Route as non-coupled 50 ohm trace.	0.2 max	inch	1
L3 length, Route as non-coupled 50 ohm trace.	0.2 max	inch	1
$R_s$	33	ohm	1
$R_t$	49.9	ohm	1

Down Device Differential Routing	Dimension or Value	Unit	Figure
L4 length, Route as coupled <b>microstrip</b> 100 ohm differential trace.	2 min to 16 max	inch	1
L4 length, Route as coupled <b>stripline</b> 100 ohm differential trace.	1.8 min to 14.4 max	inch	1

Differential Routing to PCI Express Connector	Dimension or Value	Unit	Figure
L4 length, Route as coupled <b>microstrip</b> 100 ohm differential trace.	0.25 to 14 max	inch	2
L4 length, Route as coupled <b>stripline</b> 100 ohm differential trace.	0.225 min to 12.6 max	inch	2

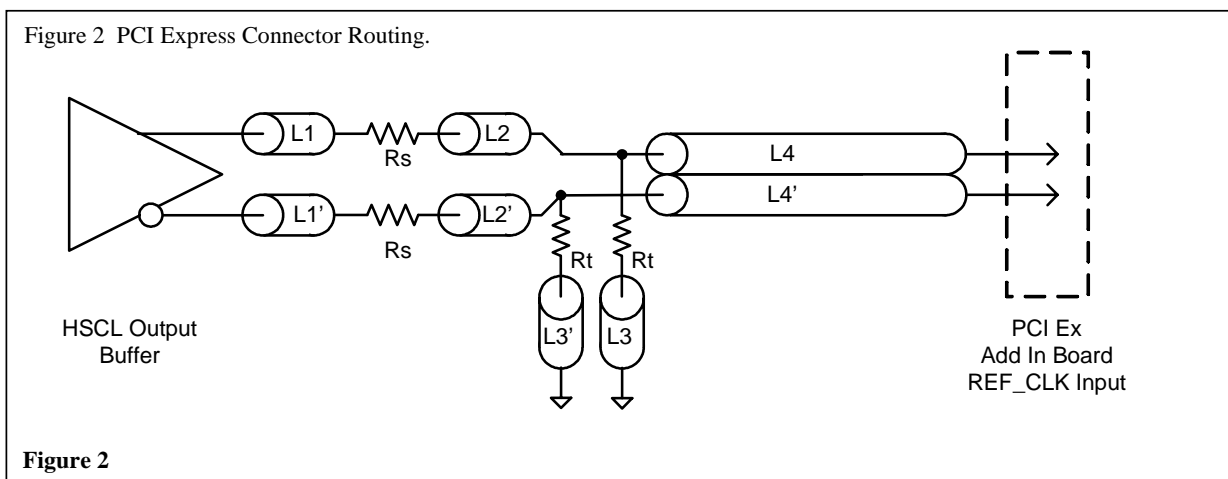
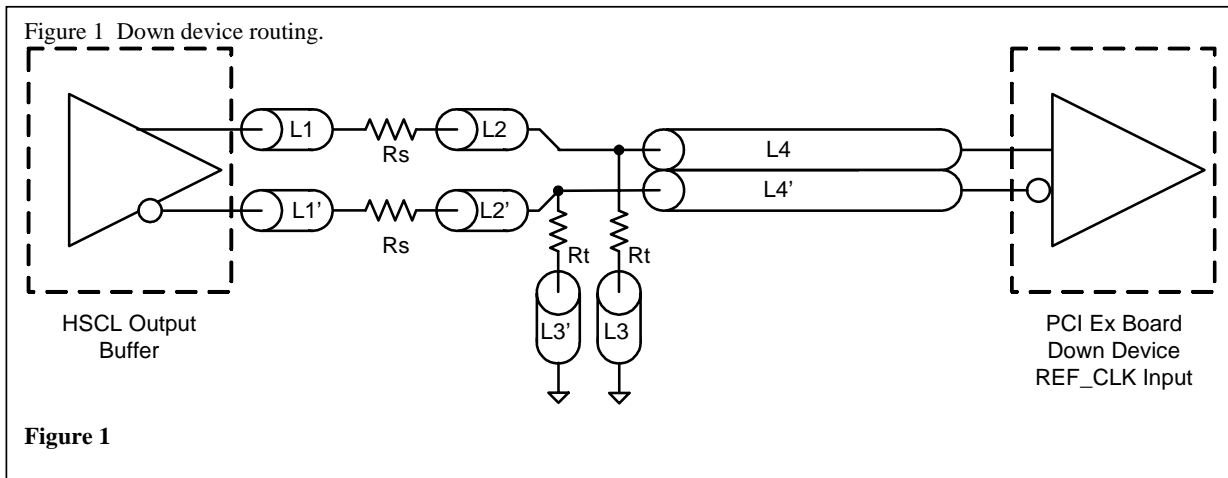



Alternative termination for LVDS and other common differential signals. Figure 3.

V <sub>diff</sub>	V <sub>p-p</sub>	V <sub>cm</sub>	R1	R2	R3	R4	Note
0.45 v	0.22v	1.08	33	150	100	100	
0.58	0.28	0.6	33	78.7	137	100	
0.80	0.40	0.6	33	78.7	none	100	ICS874003i-02 input compatible
0.60	0.3	1.2	33	174	140	100	Standard LVDS

R1a = R1b = R1

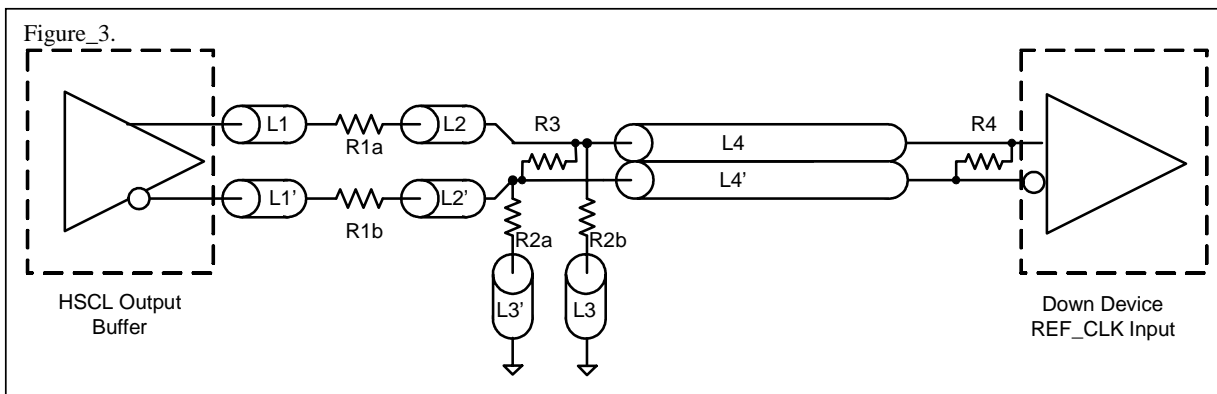

R2a = R2b = R2

Cable connected AC coupled application, figure 4

Component	Value	Note
R5a,R5b	8.2K 5%	
R6a,R6b	1K 5%	
Cc	0.1 uF	
V <sub>cm</sub>	0.350 volts	

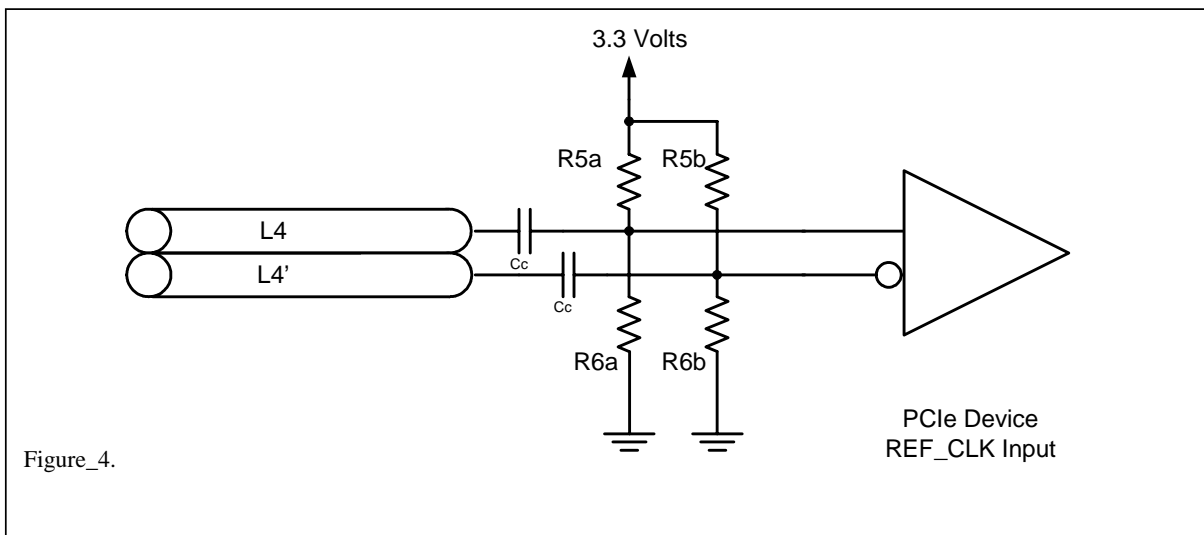

## General SMBus serial interface information for the ICS9DB1200C

### How to Write:

- Controller (host) sends a start bit.
- Controller (host) sends the write address  $DC_{(h)}$
- ICS clock will **acknowledge**
- Controller (host) sends the beginning byte location = N
- ICS clock will **acknowledge**
- Controller (host) sends the data byte count = X
- ICS clock will **acknowledge**
- Controller (host) starts sending **Byte N through Byte N + X - 1**
- ICS clock will **acknowledge** each byte **one at a time**
- Controller (host) sends a Stop bit

### How to Read:

- Controller (host) will send start bit.
- Controller (host) sends the write address  $DC_{(h)}$
- ICS clock will **acknowledge**
- Controller (host) sends the beginning byte location = N
- ICS clock will **acknowledge**
- Controller (host) will send a separate start bit.
- Controller (host) sends the read address  $DD_{(h)}$
- ICS clock will **acknowledge**
- ICS clock will send the data byte count = X
- ICS clock sends **Byte N + X - 1**
- ICS clock sends **Byte 0 through byte X (if  $X_{(h)}$  was written to byte 8).**
- Controller (host) will need to acknowledge each byte
- Controller (host) will send a not acknowledge bit
- Controller (host) will send a stop bit

Index Block Write Operation		
Controller (Host)		ICS (Slave/Receiver)
T	starT bit	
Slave Address $DC_{(h)}$		
WR	WRite	
		ACK
Beginning Byte = N		
		ACK
Data Byte Count = X		
		ACK
Beginning Byte N		X Byte
◊		
◊		
◊		
Byte N + X - 1		
		ACK
P	stoP bit	

Index Block Read Operation		
Controller (Host)		ICS (Slave/Receiver)
T	starT bit	
Slave Address $DC_{(h)}$		
WR	WRite	
		ACK
Beginning Byte = N		
		ACK
RT	Repeat starT	
Slave Address $DD_{(h)}$		
RD	ReaD	
		ACK
		Data Byte Count = X
ACK		
ACK		X Byte
◊		
◊		
◊		
		Byte N + X - 1
N	Not acknowledge	
P	stoP bit	

Note: Addresses show assumes pin 29 is low.

SMBus Table: Frequency Select Register

Byte 0	Pin #	Name	Control Function	Type	0	1	PWD
Bit 7	-	HIGH_BW#	High or Low BW	RW	High BW	Low BW	Latch
Bit 6	-	BYPASS#/PLL	Bypass (non-PLL Mode) or PLL Mode	RW	Bypass	PLL	Latch
Bit 5	-	Reserved	Reserved	RW	Reserved		X
Bit 4	-	Reserved	Reserved	RW	Reserved		X
Bit 3	-	Reserved	Reserved	RW	Reserved		X
Bit 2	-	FS2	Frequency Select 2	RW	See FS Table		Latch
Bit 1	-	FS1	Frequency Select 1	RW			Latch
Bit 0	-	FS0	Frequency Select 0	RW			Latch

SMBus Table: Output Control Register

Byte 1	Pin #	Name	Control Function	Type	0	1	PWD
Bit 7	42,41	DIF_7	Output Control (Disable = Hi-Z)	RW	Disable	Enable	1
Bit 6	38,37	DIF_6	Output Control (Disable = Hi-Z)	RW	Disable	Enable	1
Bit 5	34,33	DIF_5	Output Control (Disable = Hi-Z)	RW	Disable	Enable	1
Bit 4	30,29	DIF_4	Output Control (Disable = Hi-Z)	RW	Disable	Enable	1
Bit 3	20,21	DIF_3	Output Control (Disable = Hi-Z)	RW	Disable	Enable	1
Bit 2	16,17	DIF_2	Output Control (Disable = Hi-Z)	RW	Disable	Enable	1
Bit 1	12,13	DIF_1	Output Control (Disable = Hi-Z)	RW	Disable	Enable	1
Bit 0	8,9	DIF_0	Output Control (Disable = Hi-Z)	RW	Disable	Enable	1

SMBus Table: Output Control Register

Byte 2	Pin #	Name	Control Function	Type	0	1	PWD
Bit 7	-	Reserved	Reserved	RW	Reserved		0
Bit 6	-	Reserved	Reserved	RW	Reserved		0
Bit 5	-	Reserved	Reserved	RW	Reserved		0
Bit 4	-	Reserved	Reserved	RW	Reserved		0
Bit 3	58,59	DIF_11	Output Control (Disable = Hi-Z)	RW	Disable	Enable	1
Bit 2	53,54	DIF_10	Output Control (Disable = Hi-Z)	RW	Disable	Enable	1
Bit 1	50,51	DIF_9	Output Control (Disable = Hi-Z)	RW	Disable	Enable	1
Bit 0	45,46	DIF_8	Output Control (Disable = Hi-Z)	RW	Disable	Enable	1

SMBus Table: Output Enable Readback

Byte 3	Pin #	Name	Control Function	Type	0	1	PWD
Bit 7	42,41	OE7#	OE# Pin Readback	R	Enabled	Disabled	X
Bit 6	38,37	OE6#	OE# Pin Readback	R	Enabled	Disabled	X
Bit 5	34,33	OE5#	OE# Pin Readback	R	Enabled	Disabled	X
Bit 4	30,29	OE4#	OE# Pin Readback	R	Enabled	Disabled	X
Bit 3	20,21	OE3#	OE# Pin Readback	R	Enabled	Disabled	X
Bit 2	16,17	OE2#	OE# Pin Readback	R	Enabled	Disabled	X
Bit 1	12,13	OE1#	OE# Pin Readback	R	Enabled	Disabled	X
Bit 0	8,9	OE0#	OE# Pin Readback	R	Enabled	Disabled	X

SMBus Table: Output Enable Readback

Byte 4	Pin #	Name	Control Function	Type	0	1	PWD
Bit 7	-	Reserved	Reserved	R	Reserved		0
Bit 6	-	Reserved	Reserved	R	Reserved		0
Bit 5	-	Reserved	Reserved	R	Reserved		0
Bit 4	-	Reserved	Reserved	R	Reserved		0
Bit 3	58,59	OE11#	Output Control (Disable = Hi-Z)	R	Enabled	Disabled	X
Bit 2	53,54	OE10#	Output Control (Disable = Hi-Z)	R	Enabled	Disabled	X
Bit 1	50,51	OE9#	Output Control (Disable = Hi-Z)	R	Enabled	Disabled	X
Bit 0	45,46	OE8#	Output Control (Disable = Hi-Z)	R	Enabled	Disabled	X

Note: For an output to be enabled, BOTH the Output Enable Bit and the OE# pin must be enabled. This means that the Output Enable Bit must be '1' and the corresponding OE# pin must be '0'.

SMBus Table: Vendor &amp; Revision ID Register

Byte 5	Pin #	Name	Control Function	Type	0	1	PWD
Bit 7	-	RID3	REVISION ID	R	-	-	X
Bit 6	-	RID2		R	-	-	X
Bit 5	-	RID1		R	-	-	X
Bit 4	-	RID0		R	-	-	X
Bit 3	-	VID3	VENDOR ID	R	-	-	0
Bit 2	-	VID2		R	-	-	0
Bit 1	-	VID1		R	-	-	0
Bit 0	-	VID0		R	-	-	1

SMBus Table: DEVICE ID

Byte 6	Pin #	Name	Control Function	Type	0	1	PWD
Bit 7	-	Device ID 7 (MSB)		RW	Device ID is C0 Hex		1
Bit 6	-	Device ID 6		RW			1
Bit 5	-	Device ID 5		RW			0
Bit 4	-	Device ID 4		RW			0
Bit 3	-	Device ID 3		RW			0
Bit 2	-	Device ID 2		RW			0
Bit 1	-	Device ID 1		RW			0
Bit 0	-	Device ID 0		RW			0

SMBus Table: Byte Count Register

Byte 7	Pin #	Name	Control Function	Type	0	1	PWD
Bit 7	-	BC7	Writing to this register configures how many bytes will be read back.	RW	-	-	0
Bit 6	-	BC6		RW	-	-	0
Bit 5	-	BC5		RW	-	-	0
Bit 4	-	BC4		RW	-	-	0
Bit 3	-	BC3		RW	-	-	0
Bit 2	-	BC2		RW	-	-	1
Bit 1	-	BC1		RW	-	-	1
Bit 0	-	BC0		RW	-	-	1

**ICS9DB1200C**  
**Twelve Output Differential Buffer for PCIe Gen1/Gen2, QPI, and FBDIMM**

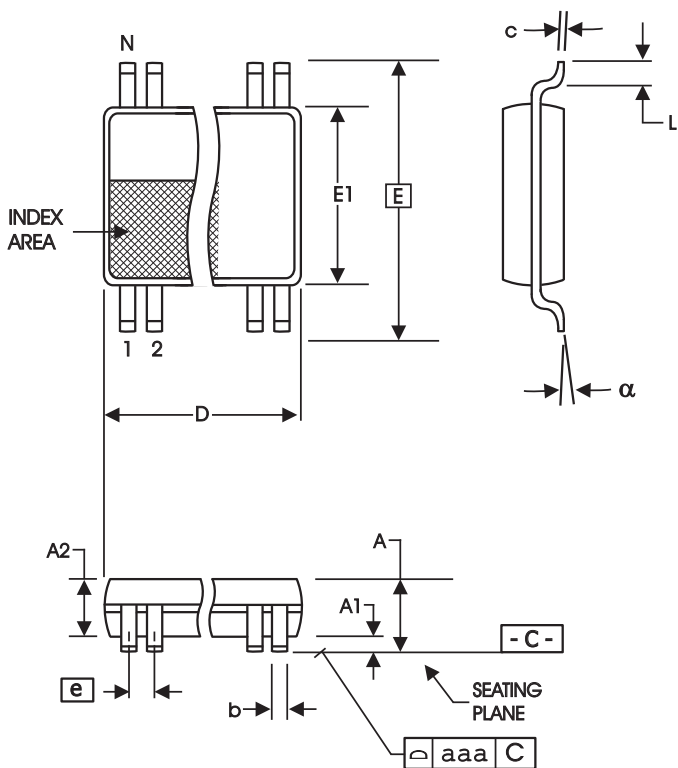

**6.10 mm. Body, 0.50 mm. Pitch TSSOP**  
**(240 mil) (20 mil)**

SYMBOL	In Millimeters		In Inches	
	COMMON DIMENSIONS	COMMON DIMENSIONS	COMMON DIMENSIONS	COMMON DIMENSIONS
A	--	1.20	--	.047
A1	0.05	0.15	.002	.006
A2	0.80	1.05	.032	.041
b	0.17	0.27	.007	.011
c	0.09	0.20	.0035	.008
D	SEE VARIATIONS		SEE VARIATIONS	
E	8.10 BASIC		0.319 BASIC	
E1	6.00	6.20	.236	.244
e	0.50 BASIC		0.020 BASIC	
L	0.45	0.75	.018	.030
N	SEE VARIATIONS		SEE VARIATIONS	
alpha	0°	8°	0°	8°
aaa	--	0.10	--	.004

**VARIATIONS**

N	D mm.		D (inch)	
	MIN	MAX	MIN	MAX
64	16.90	17.10	.665	.673

Reference Doc.: JEDEC Publication 95, MO-153

10-0039

**Ordering Information**

**ICS9DB1200CGLFT**

Example:

**ICS XXXX C G LFT**

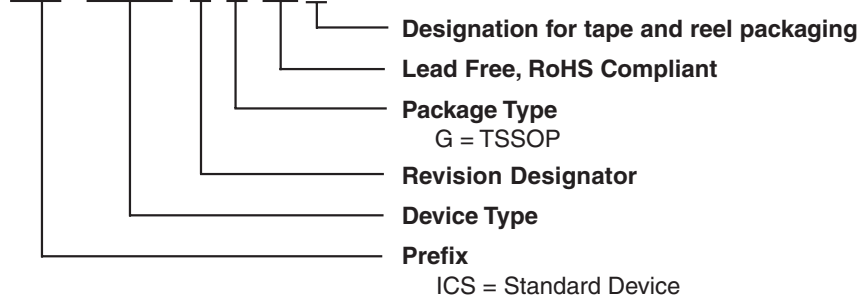

### Revision History

Rev.	Issue Date	Description	Page #
A	12/18/2007	1. Updated SMBus Serial Interface Information. 2. Release to Final.	10
B	4/7/2008	Added Input Clock Parameters	6

Innovate with IDT and accelerate your future networks. Contact:

[www.IDT.com](http://www.IDT.com)

#### For Sales

800-345-7015  
408-284-8200  
Fax: 408-284-2775

#### For Tech Support

408-284-6578  
pcclockhelp@idt.com

#### Corporate Headquarters

Integrated Device Technology, Inc.  
6024 Silver Creek Valley Road  
San Jose, CA 95138  
United States  
800 345 7015  
+408 284 8200 (outside U.S.)

#### Asia Pacific and Japan

Integrated Device Technology  
Singapore (1997) Pte. Ltd.  
Reg. No. 199707558G  
435 Orchard Road  
#20-03 Wisma Atria  
Singapore 238877  
+65 6 887 5505

#### Europe

IDT Europe, Limited  
Prime House  
Barnett Wood Lane  
Leatherhead, Surrey  
United Kingdom KT22 7DE  
+44 1372 363 339



[www.IDT.com](http://www.IDT.com)

© 2006 Integrated Device Technology, Inc. All rights reserved. Product specifications subject to change without notice. IDT and the IDT logo are trademarks of Integrated Device Technology, Inc. Accelerated Thinking is a service mark of Integrated Device Technology, Inc. All other brands, product names and marks are or may be trademarks or registered trademarks used to identify products or services of their respective owners.  
Printed in USA